

A-4400 Series Refrigerated Air Dryers Installation and Maintenance

INTRODUCTION	3
Product Overview	3
INSTALLATION PROCEDURES	4
Location	4
Unpacking the Unit	4
Conventional Wall Mounting Arrangement	4
Air Connections	5
Base Mounting Arrangement	6
Activated Carbon Filter Installation	6
Drain Connections	7
Permanent Wiring Using Conduit	8
Wiring to Air Compressor	9
COMMISSIONING	10
Gauge Correction	10
Evaporator Pressure Adjustment	10
Altitude Compensation	10
Low Ambient Temperature Compensation	11
SERVICING PROCEDURES	12
Particle Filter	12
Coalescing Oil Removal Filter	13
Replacement Coalescing Oil Removal Filter Element Kit	14

Activated Carbon Oil Vapor Removal Filter	15
Pressure Reducing Valve	15
Power On/Fail Lamp	15
Refrigeration Service	16
Condenser Fan Motor Replacement	21
Condenser	23
Air Dryer Compressor Motor Wiring Circuit	23
Excessive Vibration	24
SPECIFICATIONS	25
REPAIR INFORMATION	26

Introduction

Product Overview

The A-4400 Series Refrigerated Air Dryers are designed for continuous operation to supply dry air to pneumatic control systems. All components are selected and assembled to provide dependable service over a long period of time with a minimum amount of maintenance.

Note: For units without a factory mounted Air Purification System (consisting of a coalescing oil removal filter with integral pressure drop indicator, packed column type activated carbon oil vapor removal filter, service bypass valve, pressure reducing valve, safety relief valve, and power on/fail lamp), a properly configured system must include a coalescing oil removal filter as well as an activated carbon oil vapor removal filter as outlined in Product Data A-4000 and the Installation and Service Manual for PureFlow™ Air Compressors (Publication No. 2629).

Table 1: Ordering Data

Code Number	Flow Capacity at Rated Condition* scfm (L/s)	Air Purification System	Shipping Weight lb**
A-4412-1	12 (5.7)	Yes	72
A-4412-2	12 (5.7)	No	67
A-4417-1	17 (8.0)	Yes	78
A-4417-2	17 (8.0)	No	73
A-4423-1	23 (10.9)	Yes	78
A-4423-2	23 (10.9)	No	72

* The rated condition is 20 psig (140 kPa) supply pressure, 100 °F (38°C) saturated inlet air temperature, 100°F ambient temperature, and 80 psig (560 kPa) inlet pressure.

** lb x 0.454 = kg.

Installation Procedures

Location

The A-4400 Series Refrigerated Air Dryer must be located in an open area that will permit free circulation of air through the ends of the unit. The A-4400 requires 12 in. (305 mm) top clearance (as measured from the top of the cabinet) and 12 in. clearance at either end. When the unit is wall mounted, it is recommended that there also be 10 in. (254 mm) bottom clearance.

Unpacking the Unit

Hand protection is required when removing the A-4400 from its shipping carton. Proceed as follows:

1. Cut the two adjacent corners of the front carton panel from top to bottom, then fold the panel down. Remove the air dryer from its shipping carton through the exposed side.
2. Wearing proper eye protection and using a pair of wire cutters, reach into the air connection side of the air dryer and cut the steel packing band securing the compressor to the shipping chipboard.
3. Tip the air dryer slightly on its edge and carefully remove the steel packing band and discard. Also slide the shipping chipboard out and discard.
4. Remove and discard the packaging cardboard from behind the coalescing filter, if applicable (Models A-4412-1, A-4417-1, and A-4423-1).

Conventional Wall Mounting Arrangement

Two key slots are provided at the rear of the A-4400 for wall mounting the unit (refer to Figure 1). Install the bolts and appropriate anchors (field furnished) in the wall at 16 in. (406 mm) center-to-center spacing, in a level arrangement. Hang the A-4400 on the bolts and tighten as required.

Note: The key slots (center to center spacing) can be hand adjusted approximately 1/2 in. (13 mm) if needed when hanging the unit on the mounting bolts.

This wall mounting arrangement provides proper air circulation, allows easy access to the interior of the unit, and makes it convenient to remove the particle filter and automatic condensate drain trap assembly through the bottom of the unit for any necessary cleaning or replacement.

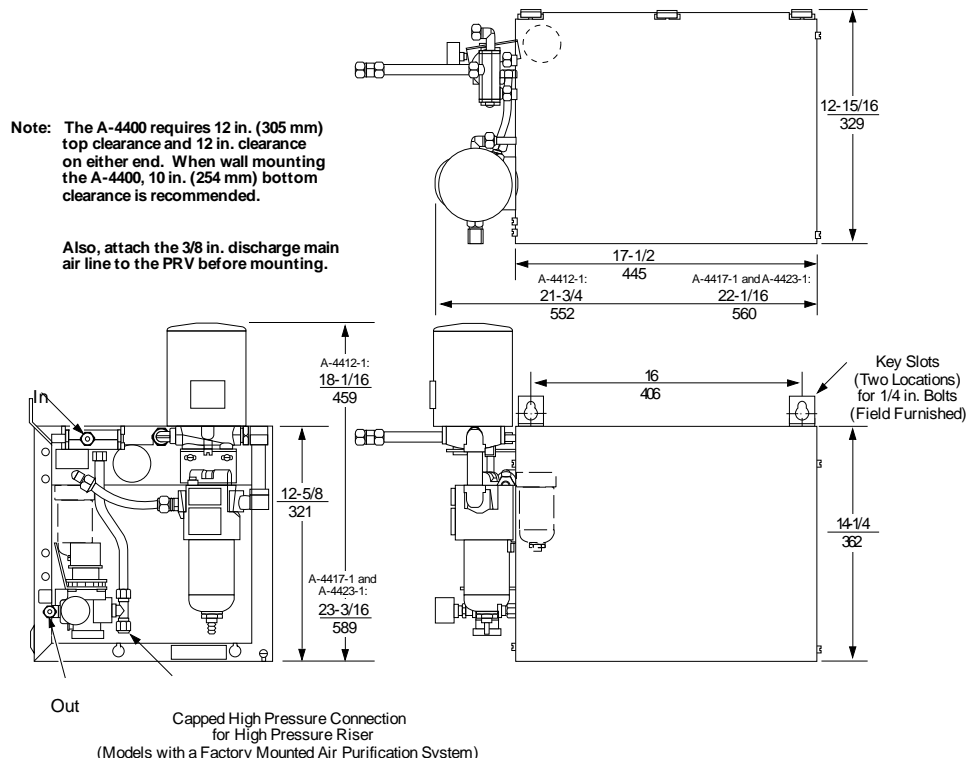

Figure 1: A-4400 Series Refrigerated Air Dryer Shown with Optional Factory Mounted Air Purification System

Dimensions $\frac{\text{in.}}{\text{mm}}$

Air Connections

The high pressure side of the compressed air line, after the compressor tank, must be connected to the 3/8 in. compression inlet air connection. On models with an optional factory mounted Air Purification System, this inlet air connection is located on the service bypass valve. These models also include a capped high pressure outlet connection (refer to Figure 1) directly ahead of the PRV. To use this connection, remove the cap and connect the high pressure outlet line to the 3/8 in. compression connection provided. Check all air line connections for leakage.

Base Mounting Arrangement

Several mounting hole patterns are provided in the base of the A-4400 (refer to Figure 2) for securing the unit to a platform. These mounting holes are sized for 1/4-20 self-tapping screws or a No. 12 nut and bolt combination (all field furnished).

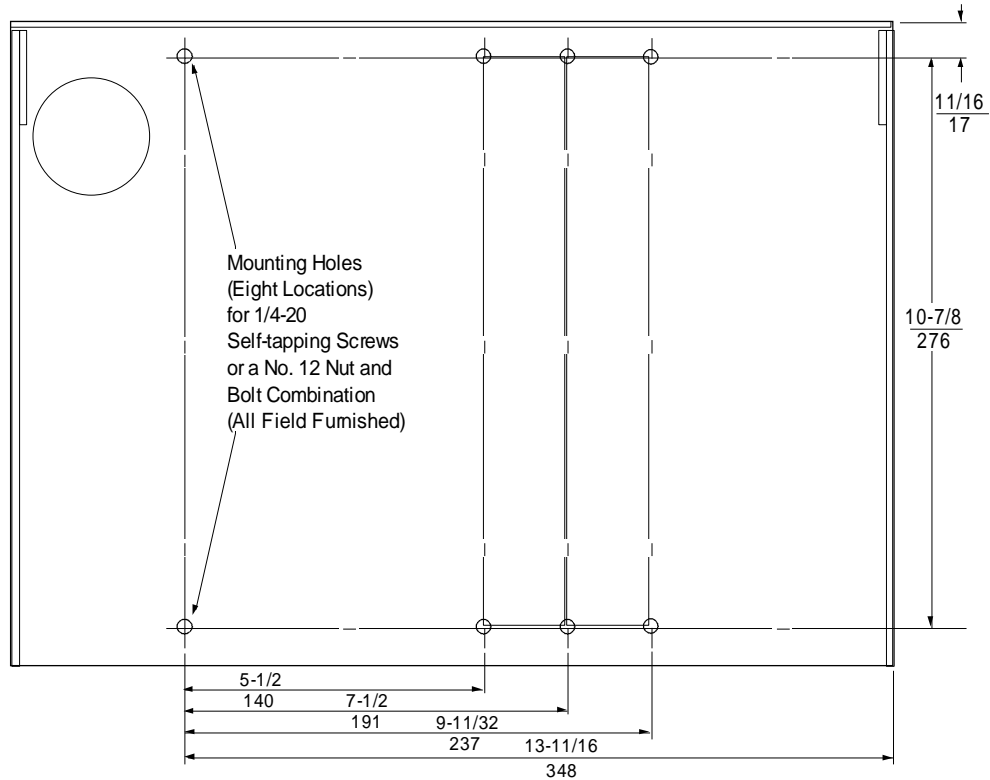

Figure 2: DryFlow A-4400 Series Refrigerated Air Dryer Base Mounting Hole Patterns (Plan View)

Dimensions $\frac{\text{in.}}{\text{mm}}$

Activated Carbon Filter Installation

On models with an optional factory mounted Air Purification System, the activated carbon oil vapor removal filter is packaged separately within the dryer shipping carton and must be installed on the unit in the field as follows:

1. Referring to Table 2, note the life of the activated carbon oil vapor removal filter element being installed.
2. Divide the element life noted in Step 1 by the average system scfm or L/s to obtain the expected life in days.

3. Use the expected life calculated in Step 2 to determine the replacement date, and record this date on the servicing label on the carbon filter element.
4. Remove the red plastic dust cap from the carbon filter pipe connection.
5. With the black sealing washer in position on the base of the carbon filter element, screw the element onto the male pipe thread and hand tighten to complete the installation.

Table 2: Carbon Filter Element Life

Carbon Filter Element Code Number	Flow Capacity	Element Life
A-4000-147	10 scfm (4.7 L/s)	4,000 scfm-Days (1,888 L/s-Days)
A-4000-146	20 scfm (9.4 L/s)	13,000 scfm-Days (6,136 L/s-Days)

Drain Connections

The automatic condensate drain trap assembly has a 1/8 in. internal NPT drain connection and the coalescing oil removal filter assembly (on air dryers with an optional factory mounted Air Purification System) has a 1/8 in. external NPT drain connection. Two styles of couplers are available for connecting the drain line to the coalescing oil removal filter assembly if needed: the F-400-20 kit is a 1/8 in. external NPT x 1/8 in. internal NPT coupler, and the F-400-10 kit is a 1/8 in. internal NPT x 1/4 in. O.D. compression coupler. Both coupler kits must be ordered separately.

Attach tubing to the connections on the automatic condensate drain trap assembly and the coalescing oil removal filter assembly (if present), keeping the runs as short as practical in order to reduce back pressure on the automatic drains. Use separate drain lines for the automatic condensate drain and the coalescing oil removal filter drain; never connect the lines together.

Note: An override feature is incorporated in the coalescing oil removal filter and automatic condensate drain trap, which allows manual draining of the bowl. To activate the override, it will be necessary to remove the tubing and connections from the 1/8 in. NPT drain connection at the bottom of the bowl. Then, using a 1/8 in. diameter or smaller rod, insert it up into the drain connection until it contacts the override needle. This will cause the bowl to drain. When the bowl has been drained, replace the connections and tubing.

Permanent Wiring Using Conduit

All A-4400 Series Refrigerated Air Dryers are furnished with a cord and plug to fit a standard 115 volt receptacle. If permanent wiring is required using conduit, proceed as follows:

1. Cut the line cord to a sufficient length so that it will reach from the compressor terminal box through Hole 1 as illustrated in Figure 3; 12 in. (305 mm) should be long enough.
2. Strip the wires back approximately 1 in. (25 mm).
3. Attach the strain relief bushing (provided with each unit) to the line cord approximately 3 in. (76 mm) from the cut end and insert it into Hole 1.
4. Connect the conduit to Hole 2 as illustrated in Figure 3, and join the leads together using the appropriate wire nuts (field furnished).

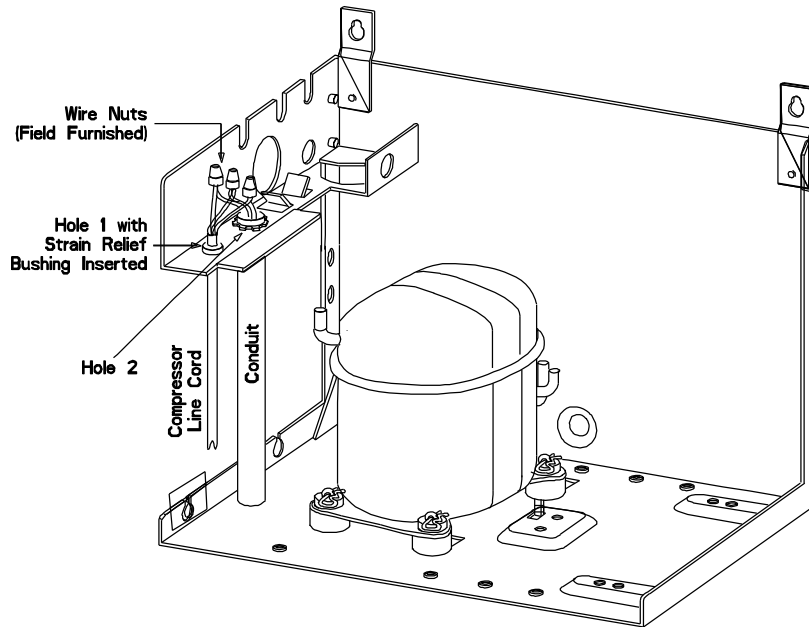

Figure 3: Permanent Wiring Using Conduit

Wiring to Air Compressor

Wiring may be run through the load side of the air compressor disconnect switch ahead of the Pressure Electric (PE) switch, as illustrated in Figure 4. Doing so will allow continuous A-4400 operation whenever the disconnect switch is closed, while control over the air compressor is retained by the PE switch.

Note: The air dryer motor voltage must match the air compressor motor voltage in order to wire the unit as illustrated in Figure 4.

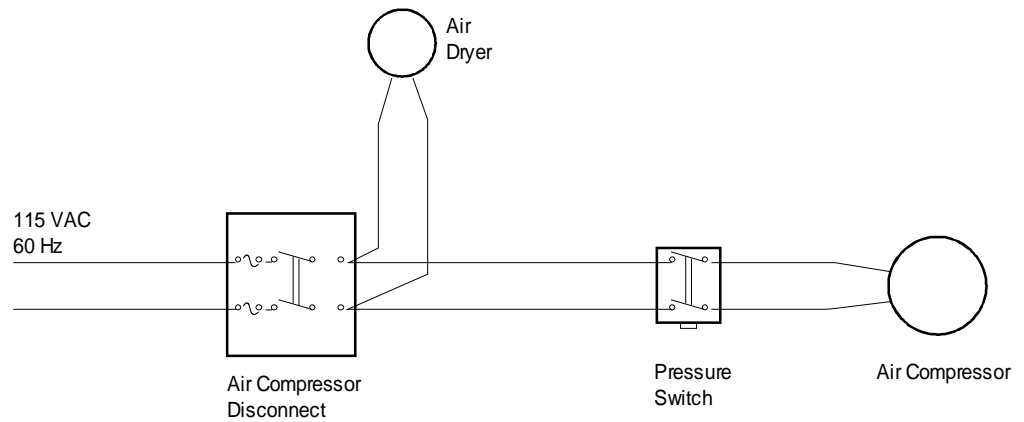

Figure 4: Single-Phase Air Compressor Motor

Commissioning

Gauge Correction

The evaporator pressure gauge is calibrated to a test gauge at the factory. Readings are recorded on a label inside the dryer cabinet base. Apply this correction to the evaporator gauge to obtain a precise reading.

Evaporator Pressure Adjustment

The A-4400 Series Refrigerated Air Dryers are factory set to protect against air side freeze-up down to ambient temperatures of 40°F (4°C) and altitudes up to 1500 ft.

Using the corrected no load evaporator pressure gauge reading and current ambient temperature, refer to the graph in Figure 5 to determine if the evaporator pressure is at the proper setting. If the value is within the acceptable operating zone as shown on the graph, then no further adjustments are necessary. If the value is not within the acceptable operating zone, then it will be necessary to adjust the expansion valve. Refer to the Refrigeration Service section and follow Steps 1 through 5 (readjusting the expansion valve setting) to properly adjust the expansion valve until the evaporator pressure gauge is at the adjusted pressure.

Note: All of the expansion valve settings are based on no load conditions, position the service bypass valve into the bypass mode. Allow the unit to run unloaded a minimum of 10 minutes prior to checking evaporator pressure or adjusting the expansion valve.

Altitude Compensation

If the air dryer is installed in high altitudes, the expansion valve will have to be adjusted to compensate for the new ambient pressure. For altitudes from 1500 to 5000 ft, increase the expansion valve setting by 2.5 psig (17.5 kPa), and for altitudes over 5000 ft, increase the expansion valve setting by 4.0 psig (28 kPa). This increase in evaporator pressure must be added to the value determined by the graph in Figure 5 to account for altitude effects. Refer to the Refrigeration Service section and follow Steps 1 through 5 (readjusting the expansion valve setting) to properly adjust the expansion valve until the evaporator pressure gauge is at the adjusted pressure.

Example:

If: Altitude = 4000 ft above sea level
 Ambient temperature = 80°F
 Evaporator pressure gauge reading at no load condition = 34.8 psig

Then: Corrected evaporator pressure = 34.8 psig + 2.5 psig = 37.3 psig

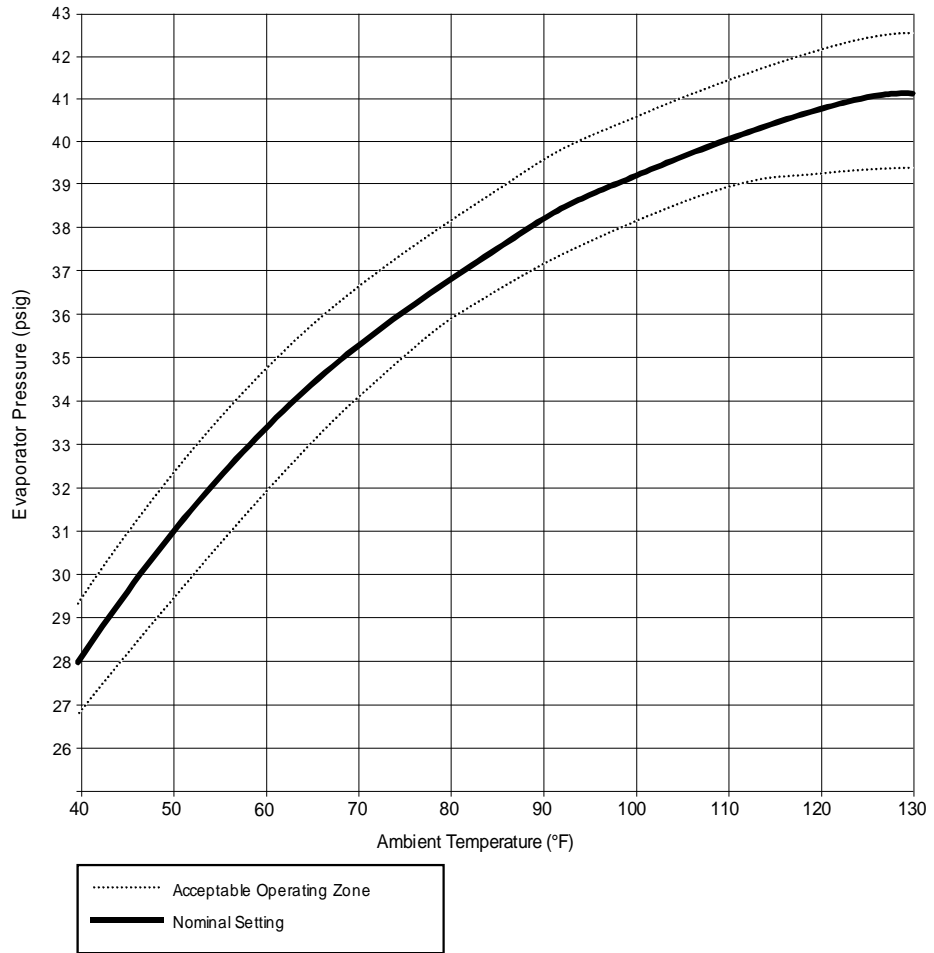

Figure 5: Evaporator Pressure vs. Ambient Temperature (Sea Level–No Load Condition)

Low Ambient Temperature Compensation

If the air dryer is used in ambient conditions between 35 and 40°F (2 and 4°C) the expansion valve must be adjusted to increase the expansion valve gauge pressure by 3 psig (21 kPa) to offset a possible freeze-up condition. This increase in evaporator pressure must be added to the value determined by the graph in Figure 5 to account for low ambient temperature effects. At high altitudes and low ambient temperatures, it will be necessary to add both pressure corrections and readjust the expansion valve. Refer to the Refrigeration Service section and follow Steps 1 through 5 (readjusting the expansion valve setting) to properly adjust the expansion valve until the evaporator pressure is at the adjusted pressure. Operation of the A-4400 in ambient temperatures below 35°F (2°C) is not recommended.

Note: If it was necessary to adjust the expansion valve settings and position the service bypass valve to bypass the air dryer, then return the service bypass valve to normal mode in order to resume operation. Also, if the pressures were changed from the normal settings, indicate the changes on the air dryer to facilitate future service.

Servicing Procedures

Particle Filter

The A-4400 Series Refrigerated Air Dryer is equipped with an automatic condensate drain trap assembly with a particle filter. The particle filter should be replaced annually or whenever the filter element appears dirty. To replace the particle filter element and/or automatic drain valve, refer to Figure 6 and proceed as follows:

1. Remove the service bypass valve locking pin and push the plunger to the right into the bypass position. Doing so will unload the pressure in the drain bowl.
2. Turn the filter bowl ① counterclockwise and remove. Also remove the O-ring ⑧.
3. Visually inspect the filter bowl ① for signs of cracking. If the bowl is cracked, it is necessary to replace the complete assembly (See Table 3, Item E ordered separately). If the bowl is not cracked, clean it using a liquid household detergent.
4. Turn the baffle ② counterclockwise and remove.
5. Remove the old particle filter element ③ and discard.
6. Install the new particle filter element (See Table 3, Item E ordered separately). Screw the baffle ② into the filter body ④ until contact is made with the filter element ③, then tighten an additional 1/4 turn.
7. To replace the auto drain (See Table 3, Item E ordered separately), remove the drain retaining nut ⑤, invert the bowl, and remove and discard the float ⑦ and seal ⑥.
8. Install the new seal ⑥ and float ⑦ and tighten the drain retaining nut ⑤ to approximately 25 in·lb of torque.
9. Reinstall the filter bowl ① and O-ring ⑧. Return the service bypass valve to normal operation by pushing the plunger left to its original position. Reinstall the locking pin to ensure that the plunger remains positioned for normal operation.

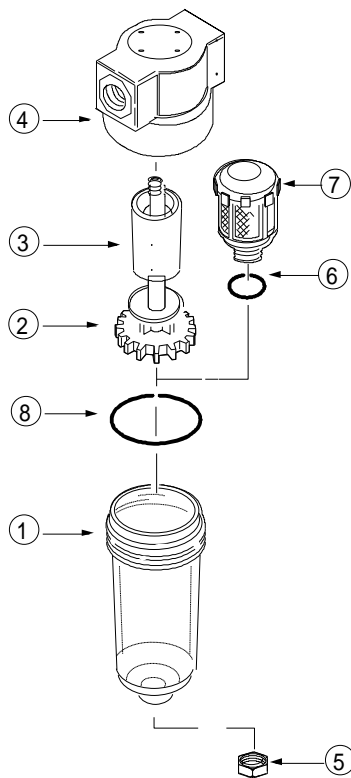

Figure 6: Particle Filter/Auto Drain Replacement

***Coalescing Oil
Removal Filter***

The coalescing oil removal filter is equipped with an automatic drain for discharging accumulations of entrapped liquids. This filter also features a pressure drop indicator integral to the top of the unit (refer to Figure 7). On a new filter, this indicator is green in color. As the pressure drop across the filter increases, a slide within the indicator moves, bringing some red color into view. When the pressure drop reaches 7.5 psig (52.5 kPa), the indicator becomes entirely red, indicating that the filter element needs to be replaced. Even if the indicator is not entirely red, it is recommended that the filter element be replaced annually.

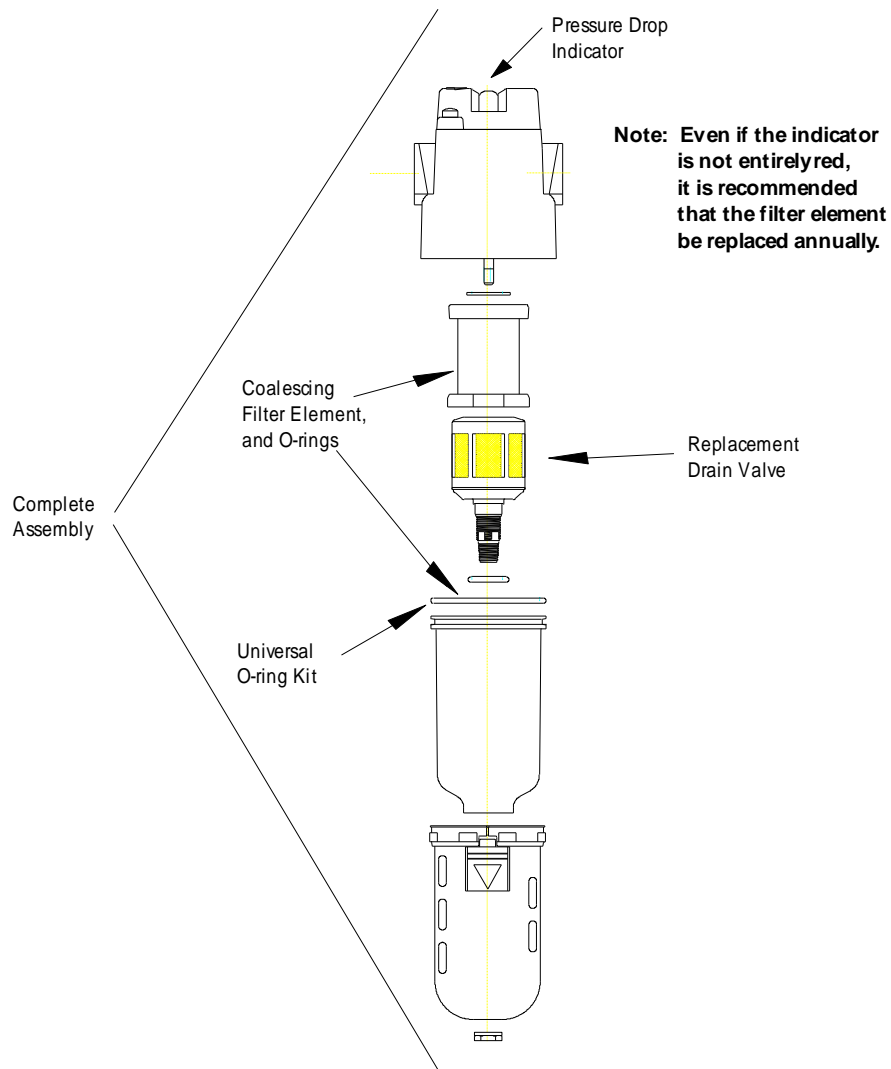

Figure 7: Coalescing Oil Removal Filter

***Replacement
Coalescing Oil
Removal Filter
Element Kit***

Each kit includes one replacement filter element, one filter element O-ring, and one filter bowl O-ring (refer to Figure 7). To replace the filter element, proceed as follows:

1. Remove the service bypass valve locking pin, and push the plunger to the right into the bypass position. Doing so will unload the pressure in the filter bowl.
2. Disconnect the drain tubing.
3. Depress the lever on the filter bowl clamp, and turn it 1/8 revolution in either direction. Drop the metal bowl guard and bowl to expose the filter element.

4. Viewing the old filter from the bottom, turn the element counterclockwise to remove it.
5. Clean the small screen around the drain seat of the automatic drain valve by turning the filter bowl upside down and tapping it lightly.
6. Visually inspect the bowl for signs of cracking. If the bowl is cracked, it will be necessary to replace the complete assembly (A-4000-1048 or A-4000-1049 ordered separately). If the bowl is not cracked, clean it and the drain valve assembly using a liquid household detergent.
7. Install the new filter element and connect the drain. For optimal filtering performance, it is recommended that the filter element be presoaked with clean oil.
8. Return the service bypass valve to normal operation by pushing the plunger left to its original position. Reinstall the locking pin to ensure that the plunger remains positioned for normal operation.

***Activated
Carbon Oil
Vapor Removal
Filter***

Refer to the white service label on the activated carbon filter element being replaced for the proper replacement procedure.

After the activated carbon filter element has been replaced, apply the white service label included with the new element, and record the next replacement date (month and year). Determine this date following the procedure outlined earlier in the Activated Carbon Filter Installation section.

***Pressure
Reducing Valve***

Upon system startup, the output of the pressure reducing valve would be approximately 15 to 20 psig (105 to 140 kPa).

Note: For optimal performance, it is suggested that the pressure reducing valve be readjusted at the normal system flow rate.

To adjust this pressure, pull up on the black knob and turn until the desired pressure is read on the low pressure gauge. Push down on the knob to lock the desired pressure setting. The safety relief valve is factory set at approximately 33 psig (231 kPa).

***Power On/Fail
Lamp***

The power on/fail lamp is located below the coalescing oil removal filter. The lamp is ON (illuminated) when there is power to the A-4400 and the compressor overload relay is closed (no overload condition exists). If the air dryer is running and the power on/fail lamp is OFF, the lamp will need to be replaced as follows:

1. Disconnect the power supply to the air dryer.
2. Cut the two leads leaving behind a convenient length of wire for use with the replacement bulb.

3. Slide the old lamp forward out of its cutout and discard; a pliers may be required.
4. Splice the replacement bulb to the existing leads using wire nuts (field furnished).
5. Slide the replacement lamp (A-4300-602 ordered separately) into the cutout and push in until it reaches the chrome stop.
6. Reconnect the power supply to the air dryer.
7. Check that the lamp is illuminated when the compressor is running.

Refrigeration Service

Note: Due to the extremely small refrigerant charge in these units (as noted on the unit nameplate), the service valve should only be used when evacuating and recharging the unit. When removing charging equipment from the service valve, care must be taken to avoid releasing any amount of refrigerant. The integral evaporator pressure gauge (with its gauge correction) on each unit should be used for all service procedures.

The A-4400 is factory set to follow the Evaporator Pressure vs. Ambient Temperature curve illustrated in Figure 5. If at no load, the evaporator pressure rises above the acceptable operating zone, one or more of the following conditions may exist.

- The ambient temperature or the air flow may be above the specified limits.
- The expansion valve may be out of adjustment or stuck in the open position.
- The condenser may be dirty.
- The condenser fan motor may be inoperative.
- The compressor may be inoperative.

If the evaporator pressure is below the acceptable operating zone (refer to Figure 5) then either the expansion valve is out of adjustment or the refrigerant charge is low.

If it is necessary to readjust the expansion valve, proceed as follows:

1. Switch the service bypass valve in order to bypass the dryer. Allow the unit to run unloaded a minimum of 10 minutes prior to adjusting the expansion valve.
2. Remove the cover from the dryer.

3. Turn the expansion valve adjusting screw to provide an evaporator pressure that corresponds to the ambient temperature determined in Figure 5. Turning the screw clockwise increases the pressure; counterclockwise decreases the pressure. One complete revolution (360 degrees) equals a pressure change of approximately 10.5 psi (73.5 kPa).

Note: If when adjusting the screw clockwise and counterclockwise, the expansion valve does not respond and the evaporator pressure remains high, a foreign object may be lodged in the expansion valve orifice. To clear the orifice, turn the expansion valve adjusting screw clockwise as far as possible, taking note of the number of revolutions made. Then return the screw counterclockwise to its original position and check the evaporator pressure.

4. Allow 20 minutes running time to stabilize the system, then reset the refrigerant pressure if required.

If after adjusting the expansion valve setting, the evaporator pressure is still too low, the refrigerant charge is probably low. To recharge the system, proceed as follows:

1. Disconnect the power supply to the air dryer.
2. Remove the filter bowl and test for possible internal refrigerant leaks by allowing a small amount of supply air to pass through the unit. Check for traces of gaseous refrigerant in the escaping air using a HFC-134a detector at the condensate drain trap (refer to Figures 10 and 11). If an internal leak is discovered, unit replacement is required. Reinstall the filter bowl when testing has been completed.
3. Using a HFC-134a detector, test for possible external refrigerant leaks, paying particular attention to all solder joints. If an external leak is discovered, proceed as follows:

Note: The service valve (as illustrated in Figures 8 and 9) provides access to the evaporator for checking or servicing. The service valve is a Schrader type valve with a sealing cap. To use the valve, unscrew the cap to expose the Schrader valve pin.

- a. Use a vacuum pump to evacuate the unit of all refrigerant into an approved refrigerant receptacle before repairing leaks.
- b. Repair any external leaks found using hard solder and flux.

4. Using a vacuum pump, evacuate any remaining air and moisture.
5. Charge the unit with R-134a refrigerant to within 1/4 ounce of the amount specified on the air dryer nameplate.
6. Remove the charging manifold and replace the cap securely on the service valve.
7. Reinstall the A-4400 cover and reconnect the power supply to the air dryer.
8. If the evaporator pressure (gauge reading plus correction) does not return to normal as illustrated in Figure 5, adjust the expansion valve as described in the Refrigeration Service section.

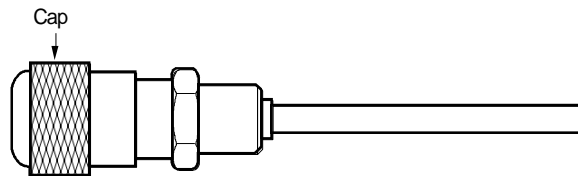

Figure 8: Service Valve Detail for Access to Evaporator

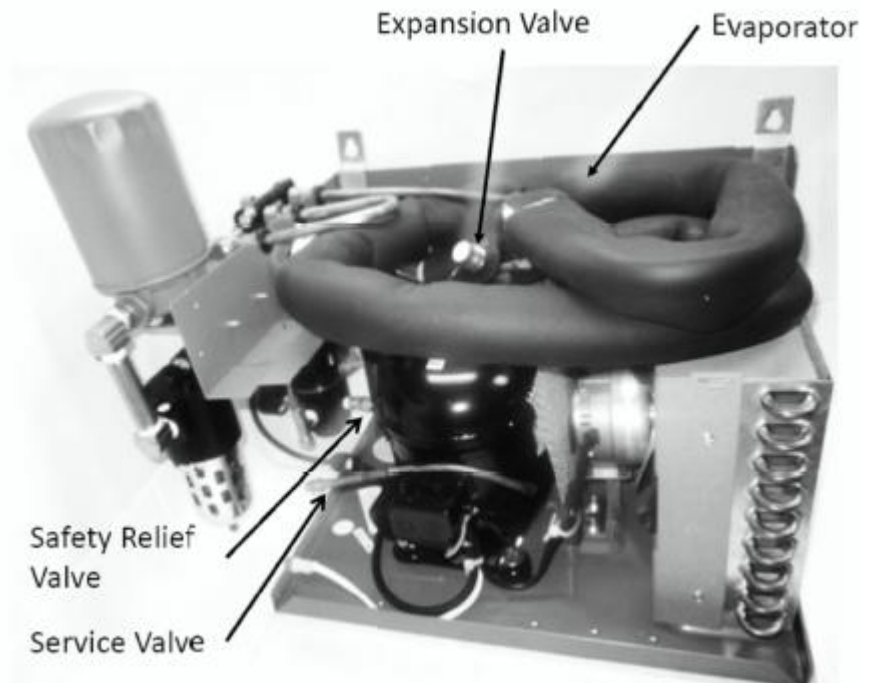

Figure 9: A-4400 Series Refrigerated Air Dryer with Cover Removed

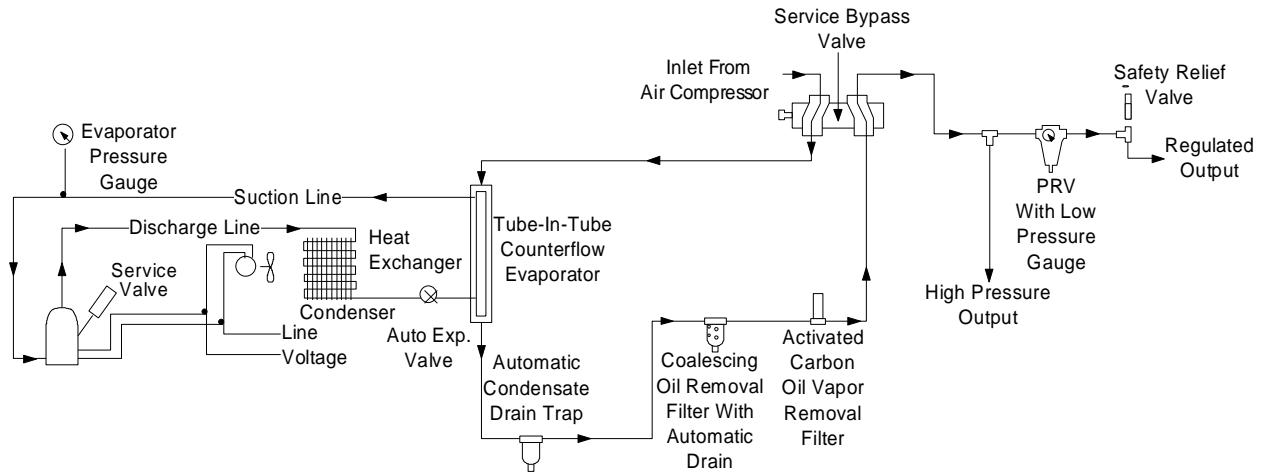

Figure 10: Schematic of A-4400 Series Refrigerated Air Dryer with Service Bypass Valve Positioned for Normal Operation (Shown with Optional Factory Mounted Air Purification System)

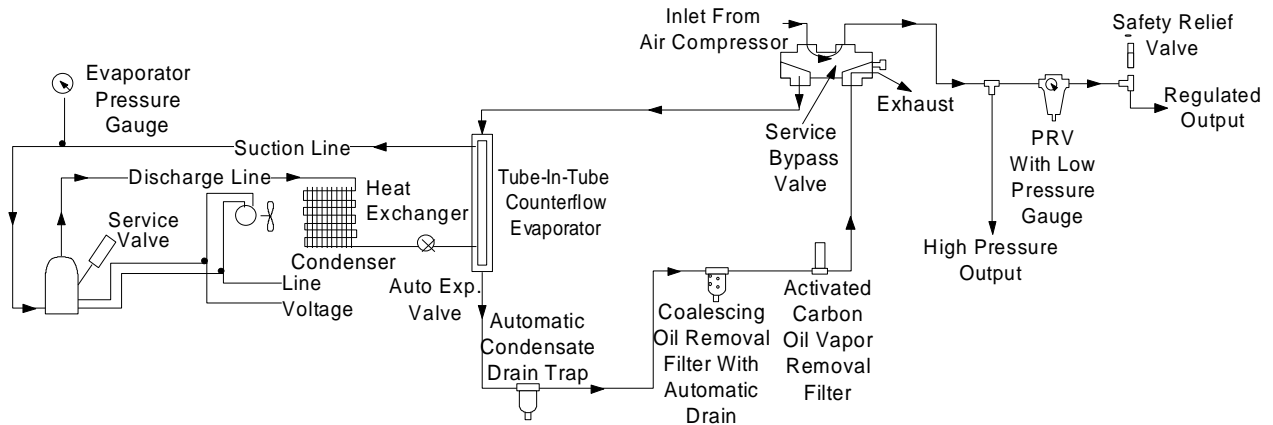

Figure 11: Schematic of A-4400 Series Refrigerated Air Dryer with Service Bypass Valve in Bypass Position (Shown with Optional Factory Mounted Air Purification System)

Condenser Fan Motor Replacement

To replace the condenser fan motor, refer to Figure 12 and proceed as follows:

1. Disconnect the power supply to the air dryer.
2. Remove the cover mounting screws and take the cover off the unit. Retain screws for reassembly.
3. Remove the cable tie securing the cord to the protecting screen.
4. Working from underneath the cabinet and using a 3/8 in. wrench, remove the two mounting screws that secure the fan assembly to the cabinet base. Retain screws for reassembly.
5. Slide the fan motor assembly out of the cabinet.
6. Noting the orientation of the fan blade, use a pliers to loosen and remove the fan blade retaining nut and the fan blade. Retain parts for reassembly.
7. Using a wire cutter, cut the two leads in a convenient location.
8. Using a 1/4 in. wrench, loosen and remove the two motor mounting screws and the fan motor support “L” bracket. Retain the screws and bracket for reassembly.
9. Noting the orientation of the motor and its leads, peel the old fan motor off of the protecting screen, leaving as much of the black vibration dampening tape behind as possible.
10. Install the replacement fan motor (A-4300-601 ordered separately) in the same orientation noted in Step 9.
11. Secure the motor and the fan motor support “L” bracket to the mounting bracket using the screws retained in Step 8.
12. Using a cable tie (field furnished), secure the motor leads to the protecting screen to keep the motor leads away from the fan blades during operation.
13. Reassemble the fan blade to the motor in the same orientation noted in Step 6, and secure it in place using the fan blade retaining nut.
14. Slide the fan motor assembly into the cabinet, over its base mounting location.
15. Secure the fan motor assembly to the cabinet base using a 3/8 in. wrench and the mounting screws retained in Step 4.

16. Splice the two leads of the replacement fan motor to the existing leads using wire nuts (field furnished).
17. Reconnect the power supply to the air dryer.
18. Check for excessive vibration. If the unit is vibrating excessively, it is likely that one or more of the fan blades is misaligned. To align the blades, refer to the Excessive Vibration section in this bulletin.
19. Reinstall the cabinet cover, and using a 1/4 in. hex-head wrench blade screwdriver, secure it in place using the cover mounting screws retained in Step 2.

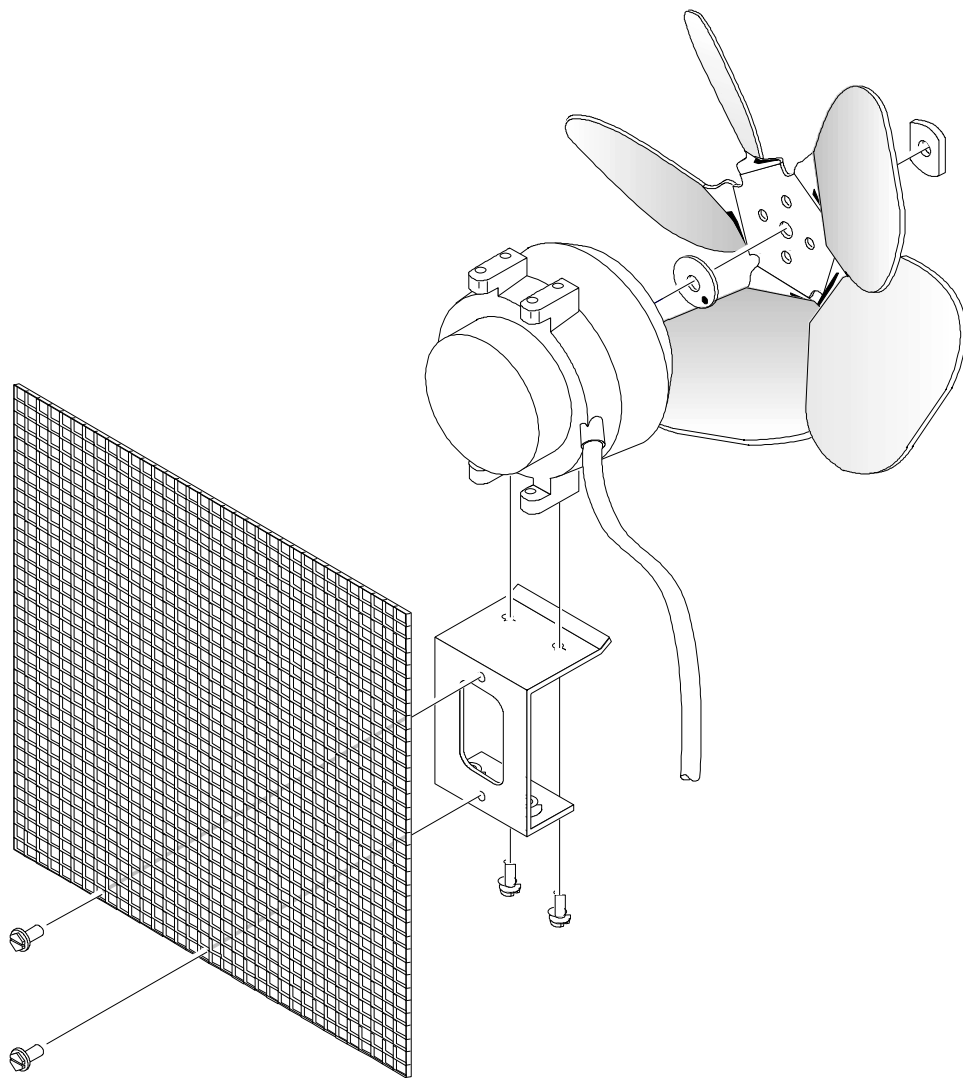

Figure 12: Condenser Fan Motor Assembly

Condenser

Check the condenser periodically for dust/particle buildup between the fins; this buildup could eventually lead to a reduction in heat transfer. If there is a buildup, remove it using a vacuum cleaner and a soft brush.

Air Dryer Compressor Motor Wiring Circuit

If there is power to the air dryer and the compressor is not operating, using an ohmmeter and referring to Figure 13, check the electrical service as follows:

1. Disconnect the power supply to the air dryer.
2. Remove the screw terminal from the overload at 3 and check for continuity between 3 and C1 on the overload. If there is no continuity, the overload may be tripped. Allow 10 minutes to pass, then check again. If there is still no continuity, the overload relay (Tecumseh 830-10041) must be replaced.
3. Pull the relay off the compressor terminals (keeping the relay upright) and check for continuity between 1 and S1. If there is continuity, the relay contacts are closed when they should be open and the relay (Tecumseh 820-10052) must be replaced.
4. Check for continuity between 1 and M1. If there is no continuity, the relay (Tecumseh 820-10052) must be replaced.
5. Check for continuity between compressor terminals C and M. At an ambient temperature of 77°F (25°C), the run winding resistance across terminals C and M should be approximately 3.1 ohms. If the run winding resistance is drastically different from the above, either replace the compressor or the entire air dryer.
6. Check for continuity between compressor terminals C and S. At an ambient temperature of 77°F (25°C), the start winding resistance across terminals C and S should be approximately 5.6 ohms. If the start winding resistance is drastically different from the above, replace either the compressor or the entire air dryer.
7. Check for continuity between compressor terminal C and the shell of the compressor. If there is continuity, either replace the compressor or the entire air dryer.

If all of the above tests prove satisfactory and the unit still fails to operate properly, replace the relay (Tecumseh 820-10052). Doing so eliminates any faulty electrical characteristics (such as improper pickup or dropout), which cannot be determined by any of the above tests. If the new relay fails to correct the problem, either replace the compressor or the entire air dryer.

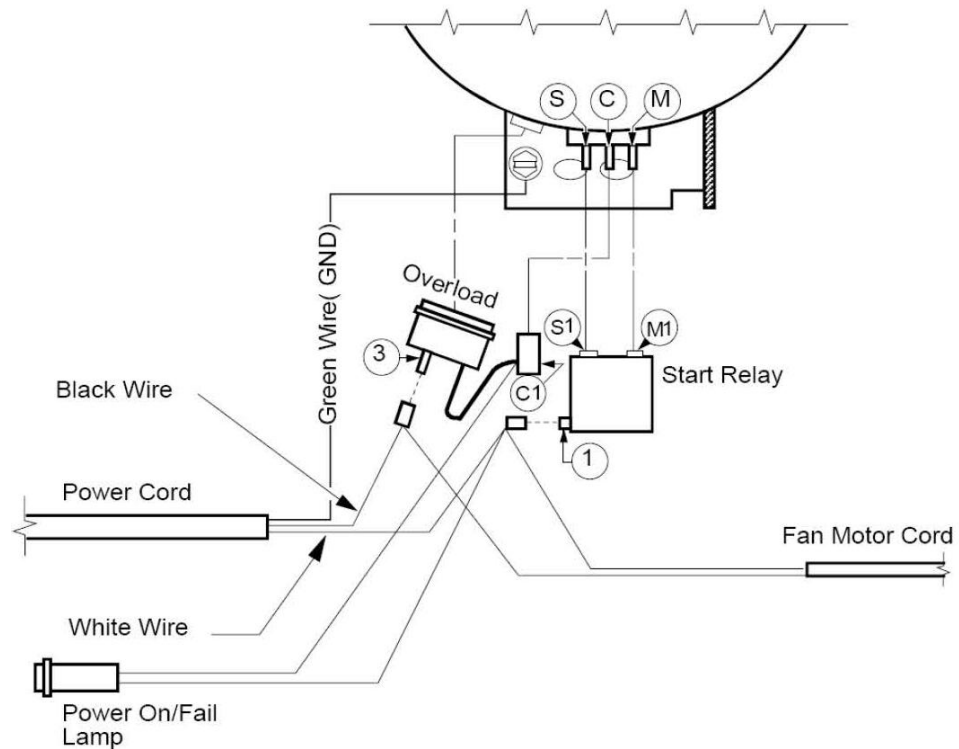

Figure 13: Air Dryer Compressor Motor Wiring Diagram

**Excessive
Vibration**

If the A-4400 appears to be vibrating excessively, it is likely that one or more of the condenser fan blades is misaligned. To align all five fan blades, proceed as follows:

1. Disconnect the power supply to the air dryer.
2. Place a reference (such as a piece of cardboard) against the trailing edge of one of the fan blades.
3. Manually rotate the fan and observe the relative alignment of all five blades with respect to the reference in Step 2.
4. If a blade appears to be out of alignment as compared to the other blades, bend the blade back into line by hand. Continue until the trailing edges of all five blades are aligned horizontally within 1/4 in. (6 mm).
5. Reconnect the power supply to the air dryer and check that the excessive vibration has been eliminated. Repeat the above procedure as necessary.

Specifications

Product	A-4400 Series Refrigerated Air Dryers
Electrical Rating	115 Volt 60 Hz, Single-phase Electrical Service
Current Draw	5.75 Amperes
Refrigerant	R-134a (HFC)
Compressor	Hermetically Sealed
Agency Listings	UL Listed, cUL Listed, Category Code SROT, File SA8490
Ambient Operating Temperature Limits	40 to 115°F (4 to 46°C) with maximum dew point of 86°F (30°C), non-condensing
Ambient Storage Temperature Limits	-40 to 140°F (-40 to 60°C)
Pressure Drop with 80 psig (560 kPa) Supply and Rated Flow	A-4412-1: 10 psig (70 kPa); A-4412-2: 4 psig (28 kPa) A-4417-1: 17 psig (119 kPa); A-4417-2: 8 psig (56 kPa) A-4423-1: 33 psig (231 kPa); A-4423-2: 15 psig (105 kPa)
Maximum Input Pressure	125 psig (875 kPa)
Connections	3/8 in. Compression Fittings for Poly tubing or Copper Tubing
Finish	Gray Enamel
Accessory (Order Separately)	A-4000-154 Manual Override for Coalescing Oil Filters

The performance specifications are nominal and conform to acceptable industry standards. For application at conditions beyond these specifications, consult the local Johnson Controls office. Johnson Controls, Inc. shall not be liable for damages resulting from misapplication or misuse of its products.

Repair Information

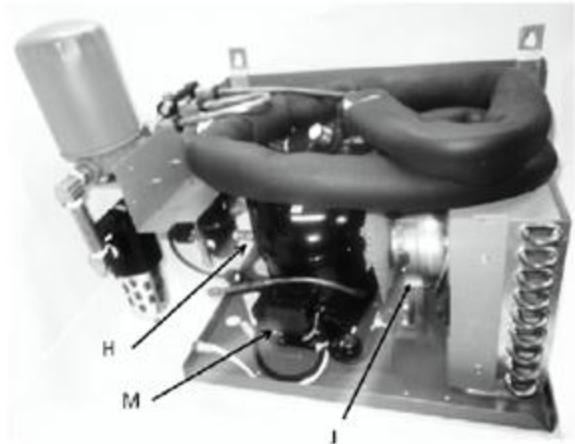

Figure 14: Repair Parts (See Table 3)

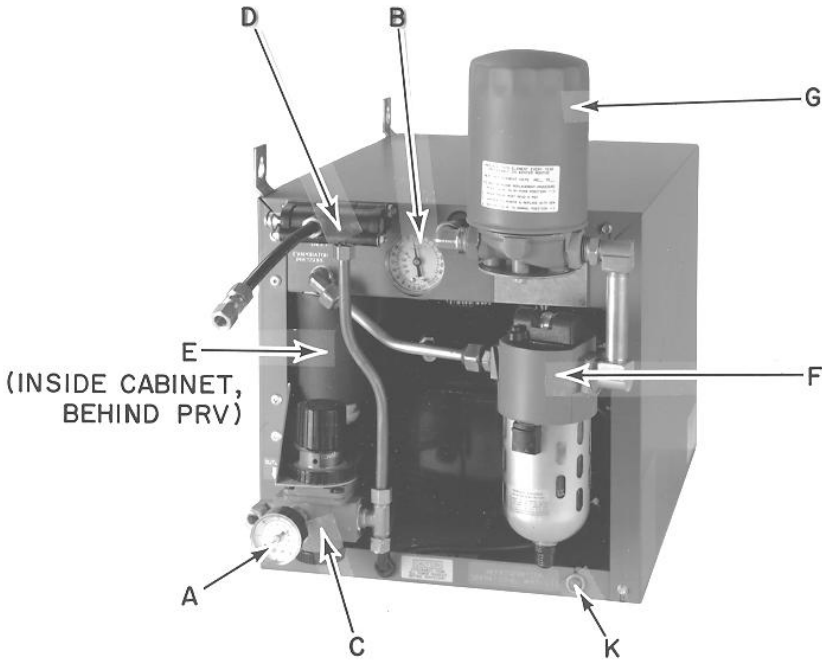

Figure 15: Repair Parts (See Table 3)

Table 3: Repair Parts

Item	Description	Shipping Weight lb*	CodeNumber		
			Date Codes through RY1 9923	Date Codes after RY1 9923	Date Codes after RY1 1351
A	System Pressure Gauge	0.1	G-2010-5		
B	Evaporator Pressure Gauge	0.2	A-4300-603		
C	Pressure Reducing Valve	1.7	R-130-14		
D	Service Bypass Valve	0.4	A-4300-600		
E	Condensate Filter: Complete Assembly	1.1	A-4000-158**	A-4000-156	
	Bowl O-Ring	0.02	A-4110-610	A-4400-610	
	Replacement Drain Valve	0.1	A-4110-607	A-4400-607	
	Particle Filter Element	0.05	A-4110-608	A-4400-608	
F	Coalescing Filter: Complete Assembly for Air Dryer Model A-4412	2.0	A-4000-1048		
	A-4417 and A-4423	2.5	A-4000-1049		
	Filter Element with O-Rings: Air Dryer Model A-4412	0.1	A-4110-604		
	A-4417 and A-4423	0.1	A-4000-604		
	Universal O-Ring Kit for Filter Element Bowl	0.03	A-4000-620		
	Replacement Drain Valve***	0.2	A-4000-6010****		
	Manual Override for Drain Valve	.25	A-4000-1054****		
G	Carbon Filter Element Only: Air Dryer Model A-4412	1.7	A-4000-632		
	A-4417 and A-4423	3.8	A-4000-633		
	H	Safety Relief Valve	0.1	A-4000-144	
J	Condenser Fan Motor	2.2	A-4300-601		
K	Power On/Fail Lamp	0.05	A-4300-602		
L	Insulating Tape (Not Shown) (Order in multiples of 30 ft)	1.2	A-4210-603		
M	Start Relay (Tecumseh P/N)	--	P82928	820-10052	
	Overload Relay (Tecumseh P/N)	--	P83458	830-10041	

* lb x 0.454 = kg.

** Includes A-4000-156 filter, new mounting bracket, mounting hardware, tubing, and drain pipe adapter.

*** The A-4000-6010 replacement drain valve does not include a bowl-to-body O-ring. If this O-ring is needed, order the A-4000-620 Kit separately.
An F-400-20 Coupling (1/8 in. external NPT x 1/8 in. internal NPT) is included with the replacement drain valve.

****The A-4000-6010 auto drain and A-4000-1054 manual override assemblies are only compatible with each other and do not work with the A-4000-610 auto drain and A-4000-154 manual override assemblies.



Building Efficiency
507 E. Michigan Street, Milwaukee, WI 53202

*Metasys® and Johnson Controls® are registered trademarks of Johnson Controls, Inc.
All other marks herein are the marks of their respective owners. © 2013 Johnson Controls, Inc.*